

## Rail Clamp

### Description

Conventional railway clamping systems face many challenges, which the Vortok Rail Clamp addresses. The Vortok Rail Clamp design is radically different to the legacy design as it guarantees a positive pre-torque angle so that the tighter the bolt is, the better the bolt holes are aligned, thus eliminating the risk of bent bolts. In tests it has been shown that bolts remain straight even at twice the recommended torque.



To reduce the friction between the clamp and the rail foot, the contact points have been made further apart than the legacy design. This reduces the force on the rail and the stress within the edge of the rail foot.

Legacy Design

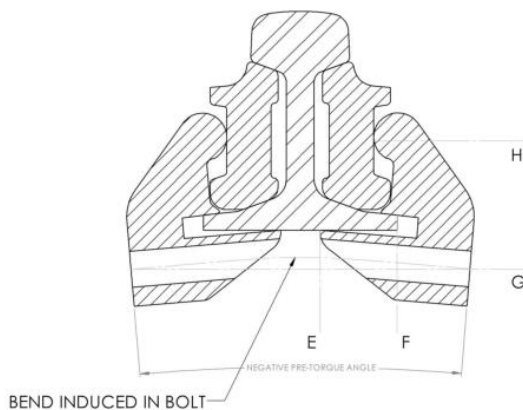

Vortok Rail Clamp

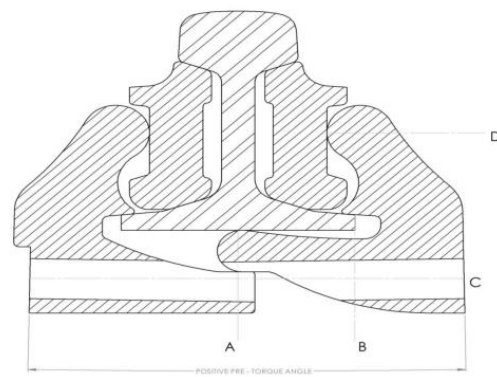

## Benefits

- Reduced rail stress through wider contact points
- Positive pre-torque angle to eliminate bolt bending
- Rapid installation
- Robust product designed for long service life

**PAT PENDING**

## Fish Plate Compatibility

The Vortok Rail Clamp is used to clamp standard fish plates to rails. A wide variety of rail and fish plate combinations are suitable for fixing by the clamp. These include but are not limited to:

Catalogue Number	Description	Supplier Code	Manufacturer
<b>113lb FLAT BOTTOM RAIL</b>			
57/054263	CEN56E1 4 Hole 6mm Gap	MJ1030	LB Foster / Coronet
57/054281	CEN56E1 4 Hole Tight Joint		LB Foster / Coronet
57/054031	CEN56E1 Dimple Maintenance Plate	MJ1032	LB Foster / Coronet
57/054031	113lb Emergency Straight Fishplate		Henry Williams
57/054029	113lb Emergency Joggled Fishplate		Henry Williams
57/054263	BS113A Standard 4 Hole Joint Fishplate		Acieries et Lamnoirs de Rives (ALR)
57/054281	BS113A Standard 4 Hole Tight Joint Fishplate		Acieries et Lamnoirs de Rives (ALR)
UIC54 Section	56E1 Emergency Straight Fishplate 1200mm Long		Acieries et Lamnoirs de Rives (ALR)
<b>UIC60 / CEN60 RAIL</b>			
57/054035	CEN 60E2 4 Hole 6mm Gap	MJ1007	LB Foster / Coronet
57/060539	CEN 60E2 4 Hole Tight Joint	MJ1008	LB Foster / Coronet
57/60101	UIC60 Emergency Joggled Fishplate		Henry Williams
57/054035	CEN60 4 Hole 6mm Gap Fishplate		Acieries et Lamnoirs de Rives (ALR)
57/060539	CEN60 4 Hole Tight Joint Fishplate		Acieries et Lamnoirs de Rives (ALR)
57/060543	CEN60 6 Hole Tight Joint Fishplate		Acieries et Lamnoirs de Rives (ALR)
57/060540	CEN60 New – 113lb New 6 Hole Fishplate		Henry Williams
57/060541	CEN60 New – 113lb 3mm Worn 6 Hole Fishplate		Corus
57/060542	CEN60 New – 113lb 6mm Worn 6 Hole Fishplate		Corus

## Specification

Clamp Thickness	60mm
Shipping Weight	10.4 kg
Shipping Dimensions	312 x 153 x 60mm
Bolt (std)	1" V-Grade Square
Bolt Head (std)	1.5" Square
Bolt (optional)	M27 Grade 10.9
Bolt Head (optional)	32 mm Hexagonal

## Part Identification

Rail Clamp	106 - 0015
Bolt	106 - 1003
Washer	106 - 1004
Nut	106 - 1005

